

## Monitoring systems

The aim of the monitoring system is:

- to detect moisture
- to locate moisture
- to detect deviations (to compare moisture related parameters with values given in the technical documentation)
- to locate disorders

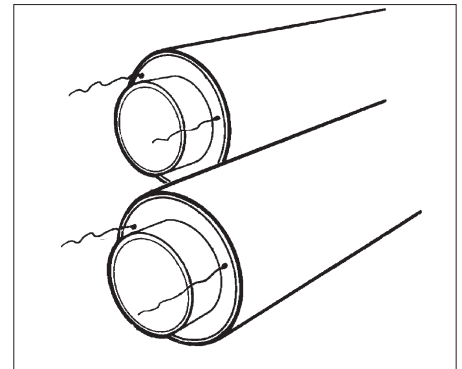

### 7.1 ALARM WIRES, DISTRICT HEATING

Two wires ( $\phi 1,5 \text{ mm}^2$  soft copper wire) are embedded in all preinsulated pipes and fittings. The position of the alarm wires are standard, 2 and 10 o'clock.

TDR speed PVF (Propagation Velocity Factor) is normally  $273 \text{ m}/\mu\text{s}$  (0.91%). The resistance in the copper wire is  $1,2 - 1,3 \Omega$  per 100 meters of wire.

### DISTRICT COOLING

Alarm cable, the Cable 3dc, is intended to be used for cooling pipelines with steel or plastic media pipe. Thanks to the cable's unique design problems with moisture condensation between the wire/wire and the media pipe along the pipelength is avoided, but above all on the pipe- and fittings ends, and in other parts of the joints.



At the production of district cooling pipes and fittings the RedDetect 3dc cable is assembled directly close to the media pipe - a fast and simple handling. Also in field joints the cable shall be located directly against the media pipe. The special design of the cable permits that impedance changes from moisture faults, of certain size, can be detected although the cable is insulated. For monitoring with the alarm cable 3dc use our alarm units RedDetect X1 ( if the cable is un-insulated at the joints) or RedDetect X3 ( if the alarm cable is un-insulated or insulated at the joints). TDR speed PVF is normally  $238 \text{ m}/\mu\text{s}$ . The resistance is  $2.54 \text{ ohm}/\text{m}$  wire.

Transfer of information from the alarm units RedDetect X1 and X3 are done as standard via broad bands or GPRS.

### 7.2 MONITORING SYSTEM

#### RedDetect® system

RedDetect® is a modern and complete monitoring system that allows automatic monitoring of isolated pipelines. The system can detect both water and various kinds of oil products. At distances up to 5000 meter detects and locates each device a fault with less than 1 meter accuracy.

Note that the accuracy depends on the alarm wires are placed at the same distance from the pipe along the entire line and that all insulated cables in the system are known and that a circuit diagram showing the actual pipeline route is available.

The system consists of both alarm devices for easy monitoring without software and the more advanced devices for central monitoring and analysis. RedDetect® system is scalable and is one of the few on the market that can easily and quickly can be developed if necessary. All devices and software can be updated wirelessly. RedDetect® System using a.o. TCP/IP protocol. This means that connection to many different types of communication types are possible. By default, we recommend network (Ethernet) or wireless communication via GPRS.

The advanced design of RedDetect® system has made it a flexible and scalable system that can be easily updated in the future. The system is also adaptable to maintenance system as chamber-monitoring via SCADA, monitoring of other types of insulated pipes, cooling pipes, oil pipelines, etc.

## The various alarm units in RedDetect ® System

### RedDetect X1

RedDetect X1 is a moisture monitoring unit for insulated pipelines. RedDetect X1 measures the insulation resistance and loop resistance and provides an acoustic and visual alarm signal if the measurement value is below the pre-installed alarm limit.

RedDetect X1 has four channels for connection of alarm wires and can locate fault on alarm wires length up to 5000 meters.



### GPRS

If you want to forward the alarms to a central monitoring place the RedDetect X1 can be updated with a built-in GPRS router. In the software XTool you can easily follow the status of your alarm units.

### RedDetect X2

RedDetect X2 is developed to monitor, detect and locate fault on insulated pipelines. RedDetect X2 measure the status of the pipe continuously and has a non-volatile memory that automatically saves the data. You can also use the X2 as a stand alone unit. The insulation resistance values and incoming alarms can be read directly in the LCD display. XTool is the monitoring software that handles the communication and presentation of data.



### RedDetect X3

X3 is designed is developed to monitor, detect and locate fault on the cooling-lines which often have problems with condensation, which occur frequently in warmer regions ex. Middle East but also in Scandinavia. RedDetect X3 has a new-developed version of TDR, TDR version 2 for best performance. RedDetect X3 is used in conjunction with the alarm cable RedDetect 3dc cable.



### RedDetect X4

RedDetect X4 is developed to monitor, detect and locate fault on insulated pipe-lines. RedDetect X4 has four (4) pcs BNC-inputs for measurement of the insulation resistance, loop resistance, battery voltage and radar curves (impedance). XTool is the monitoring software that handles the communication and presentation of data.

### RedDetect X5

RedDetect X5 is developed to monitor, detect and locate fault on insulated pipelines with oil based liquids.



### RedDetect A1

RedDetect A1 is a monitoring unit for registration of water levels, humidity, temperatures etc in chambers and for detection of moisture in insulated pipes. RedDetect A1 has four analogue respective digital and four PT1000 inputs in order to measure, for example, room temperature and humidity, flow and return water temperatures in media pipes and water levels in chambers and other wet rooms.. Enheten kan också registrera isolerade rörledningars sling- och isolationsresistans.

RedDetect A1 exists in different types for battery operation or 12 VDC power supply and with modems for different communication types.

## XTool

The RedDetect™ system is a modern and complete leak detection system that provides automatic monitoring of insulated pipes. RedDetect™ system

XTool software is the monitoring software. It handles all the communication between the computer and units, presentation of data, administration of units, user etc. XTool works against the different units in the RedDetect system and there are no restrictions for how many units that can be put to.

Xtools automatically detects the alarm devices you connect and configure your system accordingly.

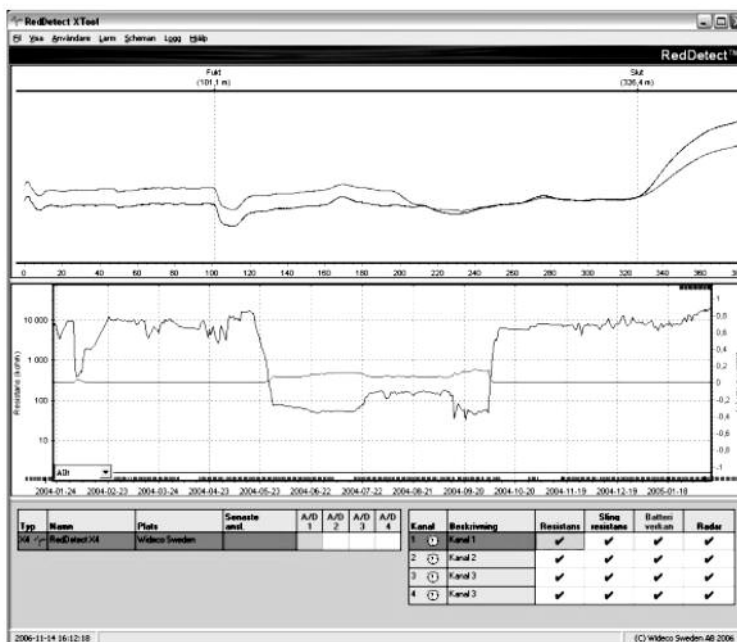

## Accessories

There are many accessories to RedDetect system. For more information visit [www.widaco.se](http://www.widaco.se).

### Connection box

MultiBox is a connection box with earth connection to the pipe which simplifies the connection of alarm wires to coaxial cable / signal



### Technical cabinet

Technical cabinet IP67 for safe installation of alarm equipment.

### Communications Modem

In case that existing networks can not be used, we recommend GPRS communications via the Internet. We can help with subscription and modem.

### Antennas

We have several different types of antennas that are designed and tested with RedDetect system.

### Cables

Coaxial cable RG62, 93 Ohm for connection of alarm devices RedDetect X2, X4, X4e for heating- or cooling pipelines. Available in lengths of 5 and 2.5 m incl. BNC connectors. Comes with red and blue bending protection. Can be extended.



Network cables are available in various lengths for connecting RedDetect alarm devices to the network equipment or external modems.

## Flexible system

The figure shows examples of different communication services. Xtools software is developed to cope with multiple users and alarm devices simultaneously and works in client / server environment. It is also possible to use remote access via Citrix as solutions for controlling software.

In XTools software is also an integrated OPC server that makes it possible to pass parameters to the overall SCADA system.

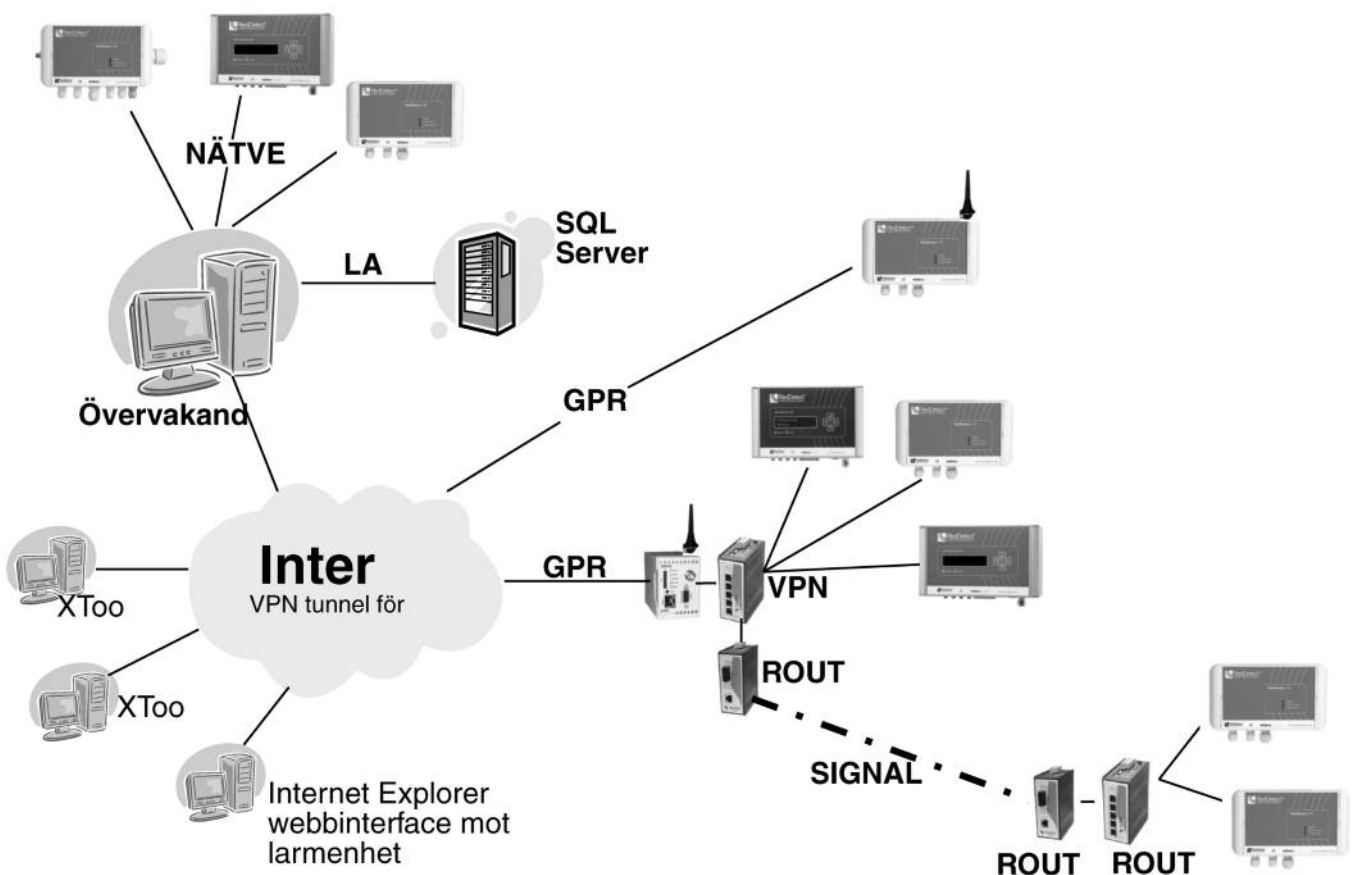

## Survey of surveillance components

Model	Rec. max measuring length (m)	Requires loop	Number of resistance Inputs	Other Inputs (pc)	Alarm limits	Power-supply	Remarks
X1	5000	Yes	2	Potential free relay output	1 kohm – 1 Mohm	External transformer (12 VDC) or Battery Pack	Optional; integrated GPRS modem /battery pack
X2	5000	Yes	2	Potential free relay output 4 pc (4-10mA or 0-10V)	1 kohm – 50 Mohm	110/230 V AC	Can be upgraded to X4
X3	2500	No	4	Potential free relay output Analog Output (4-20mA or 0-10V)	1 kohm – 50 Mohm	110/230 V AC	TDR modul version 2
X4	5000	No	4	1 pc potential free relay output Analog Output (4-20mA or 0-10V)	1 kohm – 50 Mohm	110/230 V AC	integrated TDR version 1
X5	2500	No	4	1 pc potential free relay output Analog Output (4-20mA or 0-10V)	1 kohm – 50 Mohm	110/230 V AC	TDR modul version 2
A1	5000	Ja	2	12 pc PT1000 0-10V 4-20mA Wake up	1 kohm – 1 Mohm	External transformer (12 VDC) or Battery Pack	Optional; integrated GPRS modem /battery pack

All models support the central monitoring software XTools.

For smaller installations where communication with central software is not necessary or possible, the alarm unit RedDetect X1 can be used. Alarm limits is then set manually on the device.

## Survey of surveillance components

### Artikel No.

RedDetect X1	6810-901-000-000
RedDetect X2	6810-902-000-000
RedDetect X3	6810-903-000-000
RedDetect X4	6810-904-000-000
RedDetect X5	6810-905-000-000
RedDetect A1	6810-906-000-000
RedDetect XTool	6810-907-000-000

Multibox C2	6810-900-000-000
Multibox S2	6810-910-000-000
Multibox CS	6810-915-000-000
Multibox M1	6810-920-000-000

### Alarm Outputs

Alarm Outputs PEH-detail	6890-020-000-000
Connection wires	6890-025-000-000

*Please inform regarding needed length in a sparate text line!*



*PEH detail*



*Connection wires*



*Use the connection box MultiBox C2 for easy connection of alarm wires.*

## Alarm Systems Design

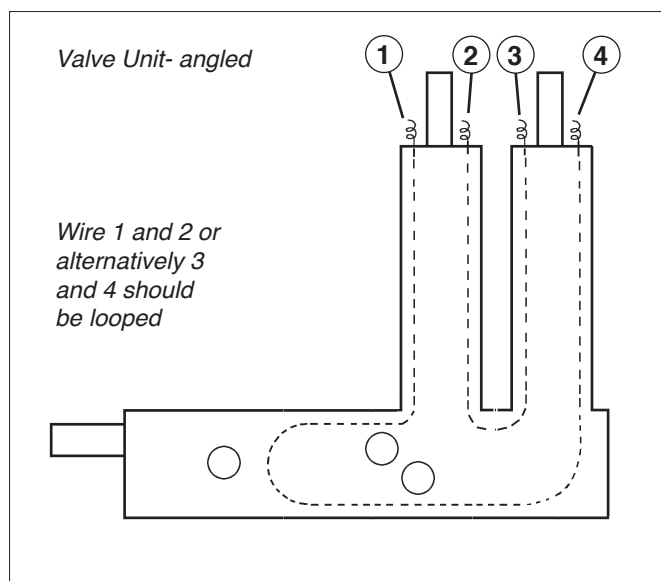
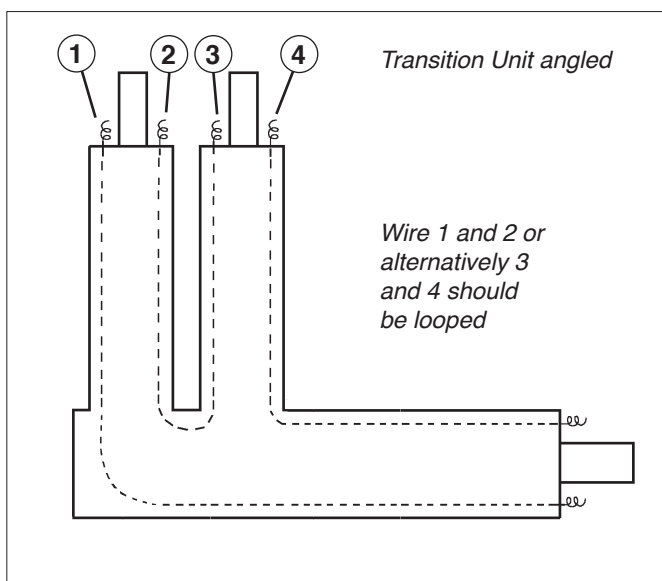
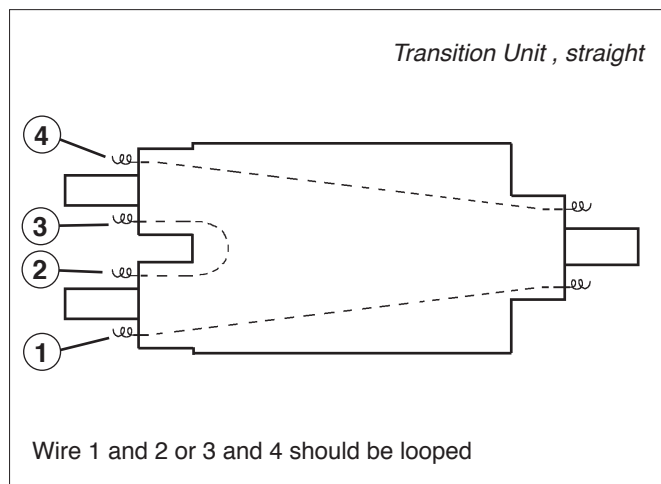
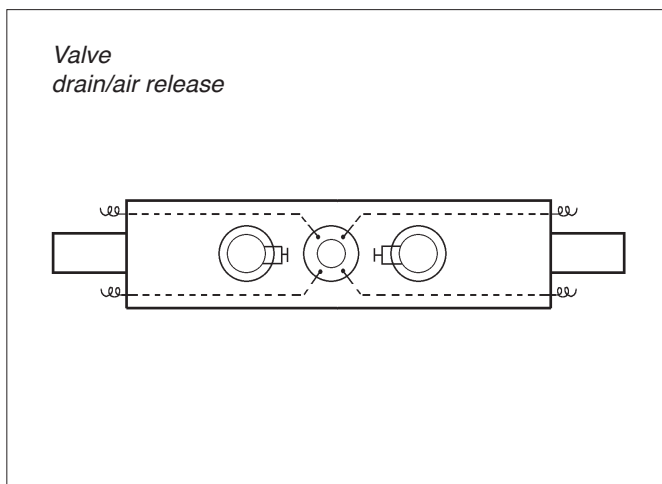
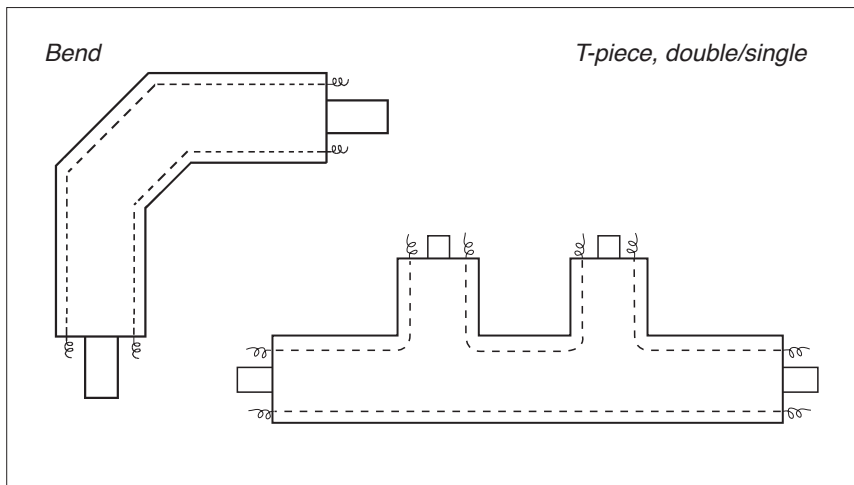
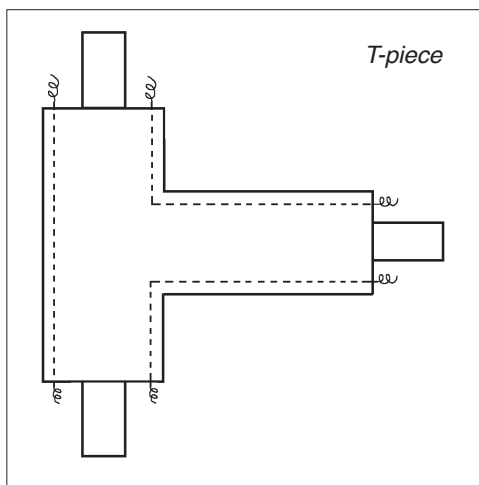

With regard to alarm wire lengths see Page 7:303

## Alarm Systems Design

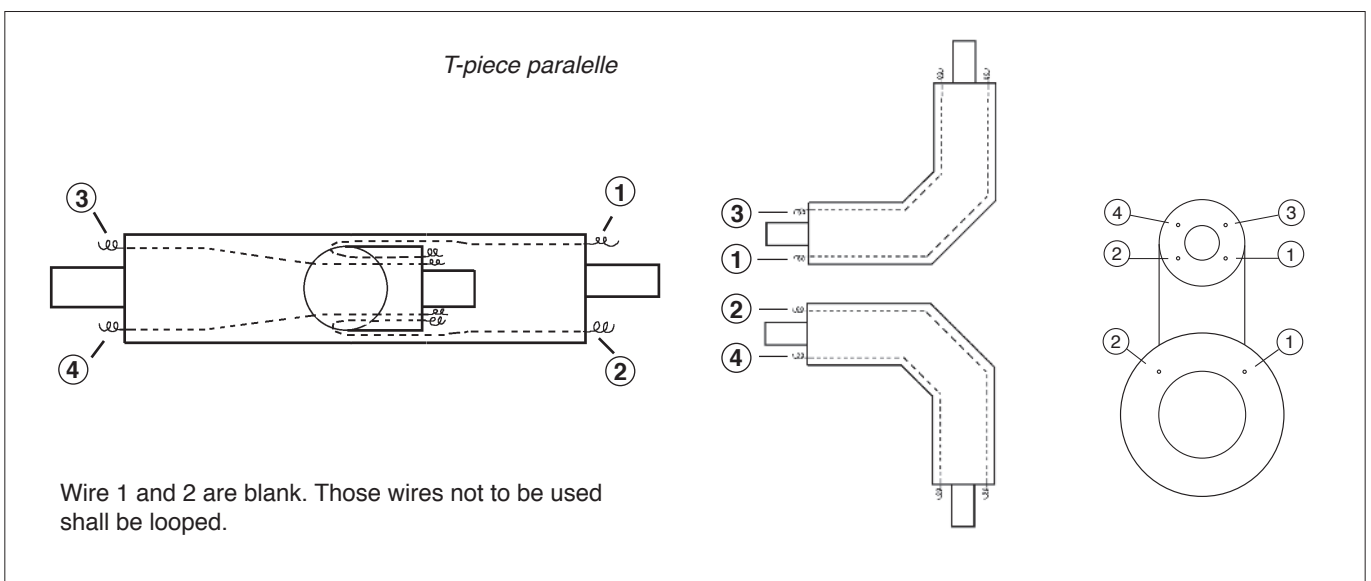
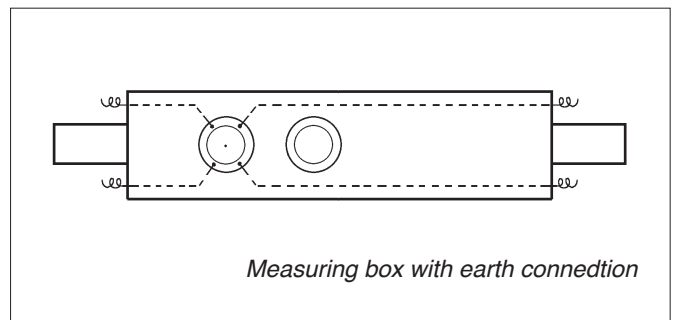
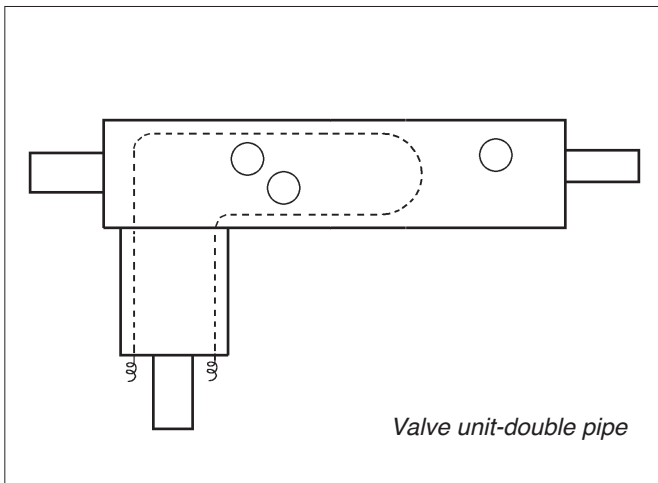
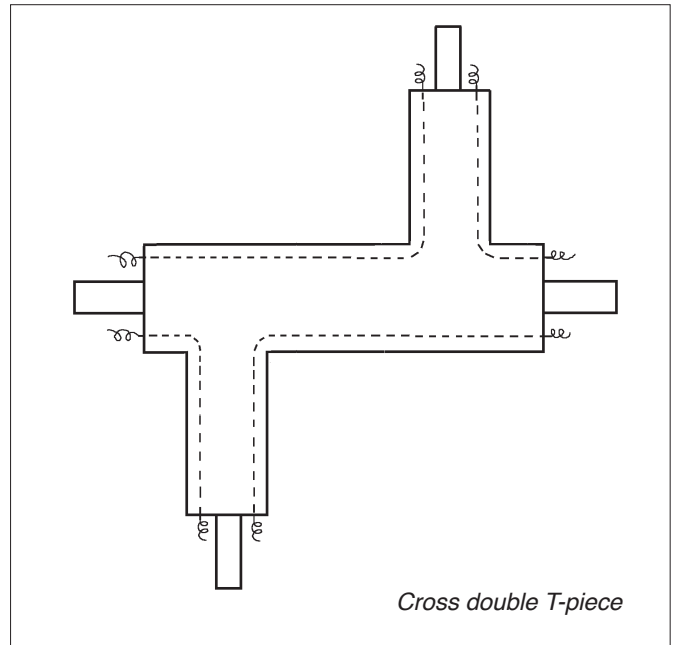
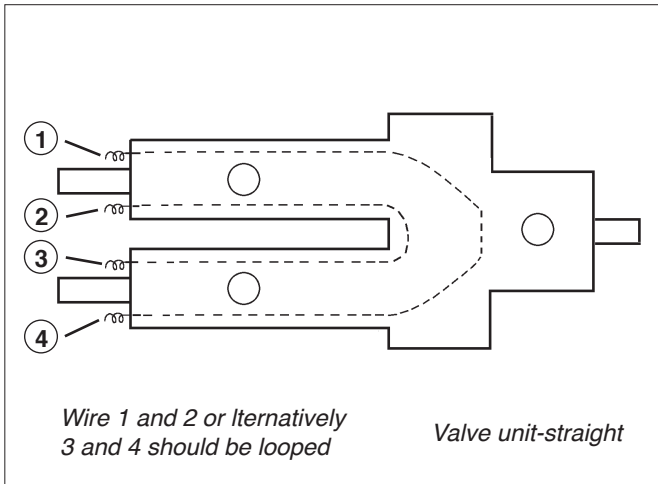

## Length of alarm wires for use with various components

The information below regarding the length of alarm wires is to be used in combination with various components installed in the district heating system and ensures accurate locating of any future faults.

The lengths are calculated from the edge of the steel pipe.

### Valve

	<i>DN 25 - 125</i>	<i>DN 150 - 250</i>	<i>DN 300</i>
Drawn alarm wires	2,3 m	2,5 m	3,0 m
Standard	1,5 m	1,5 m	1,5 m

### Transition Unit – straight

	<i>DN 25 - 50</i> L = 1400	<i>DN 65 - 150</i> L = 2250 mm
Wire 1,3	1,4 m	2,3 m
Wire 2	0,8 m	0,9 m

### Transition Unit - angled

	<i>DN 25 - 40</i>	<i>DN 50 - 100</i>	<i>DN 125 - 150</i>
Wire 1	2,0 m	2,3 m	2,5 m
Wire 2	1,5 m	1,7 m	1,8 m
Wire 3	1,7 m	1,7 m	1,8 m

### Valve Unit, angled, single pipe

	<i>DN 25 - 80</i>
Wire 1	1,3 m
Wire 2	3,7 m

### Valve Unit, straight, single pipe

	<i>DN 25 - 80</i>
Wire 1	1,9 m
Wire 2	1,4 m

### Parallel T-piece

	<i>DN 20 - 400 / DN 20 - 100</i> L = 1200 m	<i>DN 125 - 400 / DN 125 - 300</i> L = 1500 m
Wire 1,2,3,4	1,4 m	1,7 m

### Valve Unit, straight, double pipe

*DN 25 - 80*  
Wire length 3,3 m

### Valve Unit, angled, double pipe

*DN 25 - 80*  
Wire length 2,3 m

### Measuring Box

When choosing Measuring box, add for normal assembling depth:

<i>DN 25 - 125</i>	<i>DN 150 - 250</i>	<i>DN 300</i>
0,8 m	1,0 m	1,5 m