

DOUBLE PIPES

4:101

Straight pipes, standard

Powerpipes Double pipes are layed vertically with the flow pipe installed below the return pipe.

Article No. Standard, 12 m: 1503-DN-000-000

Article No. Standard, 16 m: 1504-DN-000-000

PN 16/PN25

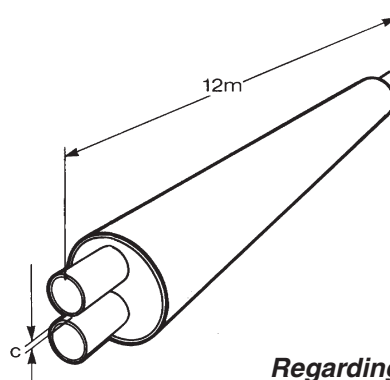

*Regarding heat losses
Please see chapter 9!*

ARTICLE NO. STANDARD, 12 m, 1503

Transmission capacity
 $\Delta T = 50^{\circ}\text{C}$

DN	Dy x s [mm]	Service pipe DY [mm]	Weight [kg/m]	C-C [mm]	[m/s]	[kW]
20	26,9 x 2,0	140	6,1	19	0,8	65
25	33,7 x 2,3	140	7,1	19	0,8	100
32	42,4 x 2,6	160	9,1	19	0,8	180
40	48,3 x 2,6	160	9,6	19	0,9	230
50	60,3 x 2,9	200	13,1	20	0,9	370
65	76,1 x 2,9	225	16,5	20	1,0	700
80	88,9 x 3,2	250	20,7	25	1,0	1.000
100	114,3 x 3,6	315	30,7	25	1,1	1.800
125	139,7 x 3,6	400	41,5	30	1,3	3.300
150	168,3 x 4,0	450	51,0	40	1,4	5.000
200	219,1 x 4,5	560	76,0	45	1,6	10.000

ARTICLE NO. STANDARD, 16 m, 1504

Transmission capacity
 $\Delta T = 50^{\circ}\text{C}$

DN	Dy x s [mm]	Service pipe DY [mm]	Weight [kg/m]	C-C [mm]	[m/s]	[kW]
100	114,3 x 3,6	315	30,7	25	1,1	1.800
125	139,7 x 3,6	400	41,5	30	1,3	3.300
150	168,3 x 4,0	450	51,0	40	1,4	5.000
200	219,1 x 4,5	560	76,0	45	1,6	10.000

DOUBLE PIPES

4:102

Straight pipes, double+

Powerpipes Double pipes are layed vertically with the flow pipe installed below the return pipe.

Article No. Standard, 12 m: 1603-DN-000-000

Article No. Standard, 16 m: 1604-DN-000-000

PN 16/PN25

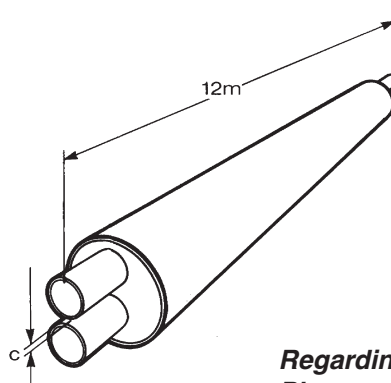

*Regarding heat losses
Please see chapter 9!*

ARTICLE NO. DOUBLE+, 12 m, 1603

Transmission capacity
 $\Delta T = 50^{\circ}\text{C}$

DN	Dy x s [mm]	Service pipe DY [mm]	Weight [kg/m]	C-C [mm]	[m/s]	[kW]
20	26,9 x 2,0	160	6,7	19	0,8	65
25	33,7 x 2,3	160	7,8	19	0,8	100
32	42,4 x 2,6	180	9,9	19	0,8	180
40	48,3 x 2,6	180	10,3	19	0,9	230
50	60,3 x 2,9	225	14,0	20	0,9	370
65	76,1 x 2,9	250	17,6	20	1,0	700
80	88,9 x 3,2	280	22,8	25	1,0	1.000
100	114,3 x 3,6	355	33,9	25	1,1	1.800
125	139,7 x 3,6	450	46,3	30	1,3	3.300
150	168,3 x 4,0	500	56,5	40	1,4	5.000

ARTICLE NO. DOUBLE+, 16 m, 1604

Transmission capacity
 $\Delta T = 50^{\circ}\text{C}$

DN	Dy x s [mm]	Service pipe DY [mm]	Weight [kg/m]	C-C [mm]	[m/s]	[kW]
100	114,3 x 3,6	355	33,9	25	1,1	1.800
125	139,7 x 3,6	450	46,3	30	1,3	3.300
150	168,3 x 4,0	500	56,5	40	1,4	5.000

DOUBLE PIPES

4:103

Straight pipes, double ++

Powerpipes Double pipes are layed vertically with the flow pipe installed below the return pipe.

Article No. Standard, 12 m: 1703-DN-000-000

Article No. Standard, 16 m: 1704-DN-000-000

PN 16/PN25

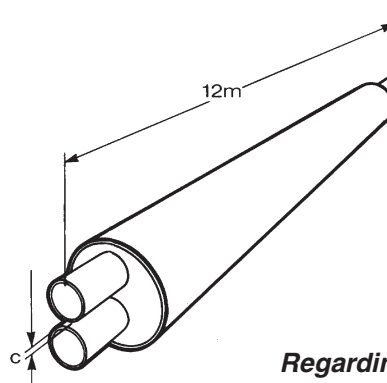

*Regarding heat losses
Please see chapter 9!*

ARTICLE NO. DOUBLE++, 12 m, 1703

Transmission capacity
 $\Delta T = 50^{\circ}\text{C}$

DN	Dy x s [mm]	Service pipe DY [mm]	Weight [kg/m]	C-C [mm]	[m/s]	[kW]
20	26,9 x 2,0	180	7,4	19	0,8	65
25	33,7 x 2,3	180	8,5	19	0,8	100
32	42,4 x 2,6	200	10,6	19	0,8	180
40	48,3 x 2,6	200	11,1	19	0,9	230
50	60,3 x 2,9	250	15,1	20	0,9	370
65	76,1 x 2,9	280	19,7	20	1,0	700
80	88,9 x 3,2	315	24,9	25	1,0	1.000
100	114,3 x 3,6	400	37,8	25	1,1	1.800
125	139,7 x 3,6	500	51,8	30	1,3	3.300
150	168,3 x 4,0	560	63,7	40	1,4	5.000

ARTICLE NO. DOUBLE++, 16 m, 1704

Transmission capacity
 $\Delta T = 50^{\circ}\text{C}$

DN	Dy x s [mm]	Service pipe DY [mm]	Weight [kg/m]	C-C [mm]	[m/s]	[kW]
100	114,3 x 3,6	400	37,8	25	1,1	1.800
125	139,7 x 3,6	500	51,8	30	1,3	3.300
150	168,3 x 4,0	560	63,7	40	1,4	5.000

DOUBLE PIPES

4:104

Straight pipes for cut-to-length

PN 16/PN25

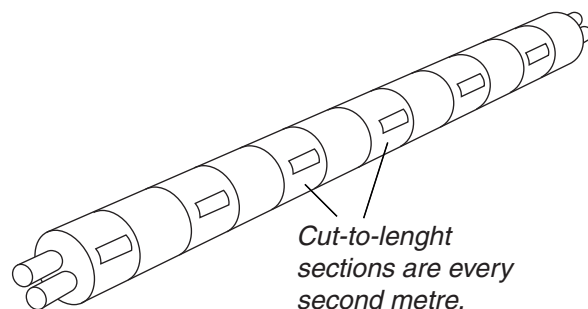

Cut-to-length pipes are manufactured in all dimensions, as given in section 4:101. In these pipes the steel service pipe is covered by a plastic foil every second metre along the entire pipe length. This arrangement allows easy removal of the foam from the steel in the sections. These sections of the pipe are indicated on the outside casing pipe. Whole lengths or parts of pipes cut-to-length can be installed at any place in a district heating distribution system.

ARTICLE NO. 1513, 1613, 1713 (12m)

L = 12 m

Article No..

1513-DN-000-000 (STANDARD)

1613-DN-000-000 (DOUBLE+)

1713-DN-000-000 (DOUBLE++)

For measurement details, please see straight pipes!

Pipes are available with «center cut»

Above should be indicated in a separate line of text.

An example of how to order:

Cut- to-length pipe Double pipe Standard DN 2*100, has Article No. 1513-100-000-000.

Curved pipes

PN 16/PN25

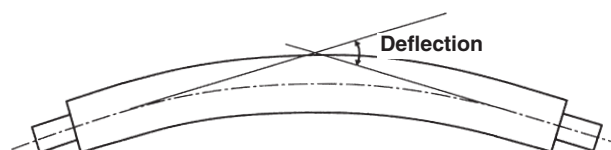

ARTICLE NO. 1523, 1623, 1723 (12 m)

ARTICLE NO. 1524, 1624, 1724 (16 m)

Double pipe DN	Max. deflection		Anm.
	L = 12 m	L = 16 m	
25 - 65	30°		To be bent at installation site
50 - 80	30°		Bent at Powerpipe works
100	30°	20°	Bent at Powerpipe works
125 - 150	30°	25°	Bent at Powerpipe works
200	25°	32°	Bent at Powerpipe works

Accuracy of manufacture DN 2*80 - 2*200 +/- 2°

Steel service pipe In the manufacturing of curved pipes welded steel pipes are used.
For manufacturing reasons alarm wires are placed in the neutral position.

Article No..

1523-DN-000-000 (STANDARD)

1623-DN-000-000 (DOUBLE+)

An example of how to order:

Curved Double pipe L = 12m with dim DN 2*100, standard,
has Article No. 1523-100-000-000.

Deflection shall be stated in a separate line of text.

Curved pipes

Deflection versus design radius

PN 16/PN25

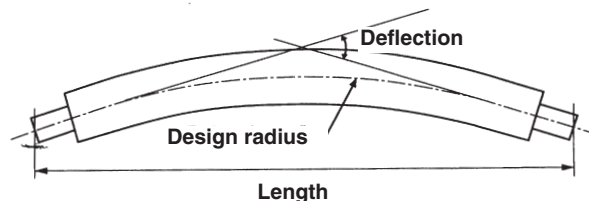

CORRELATION BETWEEN DEFLECTION AND DESIGN RADIUS

Deflection	Design radius L = 12 m	Deflection	Design radius L = 12 m
1°	690	21°	33,0
2°	345	22°	31,0
3°	230	23°	30,0
4°	170	24°	29,0
5°	140	25°	28,0
6°	115	26°	27,0
7°	98	27°	26,0
8°	86	28°	25,0
9°	76	29°	24,0
10°	69	30°	23,2
11°	62	31°	22,5
12°	57	32°	21,8
13°	53	33°	21,1
14°	49	34°	20,5
15°	46	35°	20,0
16°	43	36°	19,4
17°	40	37°	18,9
18°	38	38°	18,4
19°	36	39°	18,0
20°	34	40°	17,5

The pipes cannot be bent along its entire length. At each pipe end a straight part will remain, which shall be approximately 2 meters in length.

This deviation from an ideal curved pipe radius is to be compensated when installing the pipe by making the pipe trench approximately wider at center.

The widening should be ~200 mm at deviation < 10°

The widening should be ~500 mm at deviation > 10°

Curved pipes

Elastic radius

PN 16/PN25

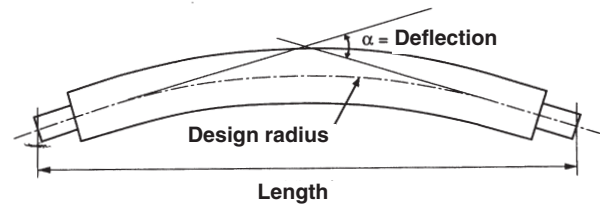

ELASTIC RADIUS

Dimension	Elastic radius m	Deflection/ 12 m
25	15	45°
40	21	31°
50	27	25°
65	34	20°
80	40	17°
100	52	13°
125	63	11°
150	76	9°
200	98	7°

The above table shows the elastic radius which is the maximum radius or deflection that can be allowed without permanent deformation in the steel pipe.

DOUBLE PIPES

4:201

Bend

PN 16/PN25

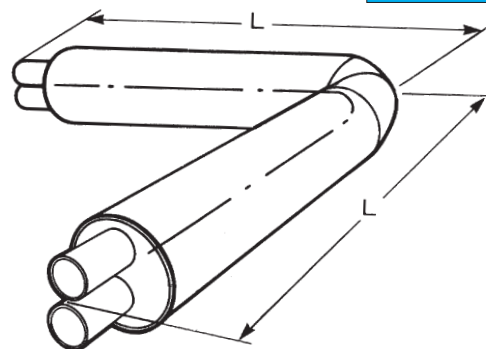

ARTICLE NO. 2500, 2600, 2700

DN	Service pipe Dy x s [mm]	STANDARD 2500	DOUBLE+ 2600	DOUBLE++ 2700	L [mm]
		Jacket pipe DY [mm]	Jacket pipe DY [mm]	Jacket pipe DY [mm]	
20	26,9 x 2,0	140	160	180	1000
25	33,7 x 2,3	140	160	180	1000
32	42,4 x 2,6	160	180	200	1000
40	48,3 x 2,6	160	180	200	1000
50	60,3 x 2,9	200	225	250	1000
65	76,1 x 2,9	225	250	280	1000
80	88,9 x 3,2	250	280	315	1000
100	114,3 x 3,6	315	355	400	1000
125	139,7 x 3,6	400	450	500	1000
150	168,3 x 4,0	450	500	560	1000
200	219,1 x 4,5	560			1000

Bends are, as standard, available as 90° and 45°.

Bends having other degrees such as 75°, 60°, 30° and 15° and bends having leg lengths other than specified in the above table can be delivered on special request.

Article No..

2500-DN-degree of bend-000 (STANDARD)

2600-DN-degree of bend-000 (DOUBLE+)

2700-DN-degree of bend-000 (DOUBLE++)

Space for sleeve

In order to adequately fit sleeve
Installation of DN2*50–2*125 an
Extended shank 1200 x 1200 mm
is offered. State suffix: 999

An example of how to order:

Bend Double pipe Standard dim DN 2*80, 90°
has Article No. 2500-080-090-000.

DOUBLE PIPES

4:202

Termination bend, 90°

The termination bend is delivered with seal for the insulation at one pipe end. This seal prevent water from penetrating during the construction period. (regarding DN*25-65)

The built-in alarmwires are linked outside the sealing.

PN 16/PN25

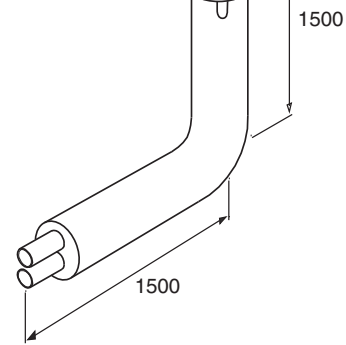

TERMINATION BEND 2510, 2610, 2710

STANDARD

DOUBLE+

DOUBLE++

DN	Service pipe Dy x s [mm]	2510	2610	2710
		Service pipe Dy [mm]	Service pipe Dy [mm]	Service pipe Dy [mm]
20	26,9 x 2,0	140	160	180
25	33,7 x 2,3	140	160	180
32	42,4 x 2,6	160	180	200
40	48,3 x 2,6	160	180	200
50	60,3 x 2,9	200	225	250
65	76,1 x 2,9	225	250	280
80	88,9 x 3,2	250	280	315
100	114,3 x 3,6	315	355	400
125	139,7 x 3,6	400	450	500
150	168,3 x 4,0	450	500	560

The termination bend is also available in versions with the upward rise of 90 °, see figure below!
Termination bend 90°, with another leg length and other degree of bend can be supplied on request.

Article No.

2510-DN-000-000 (STANDARD)

2610-DN-000-000 (DOUBLE+)

2710-DN-000-000 (DOUBLE++)

Pipe under - right prefix 031

Pipe under - left prefix 032

An example of how to order:

Termination bend Double Standard pipe with dim DN 2*50, standard design under - rise right has Article No. 2510-050-000-031.

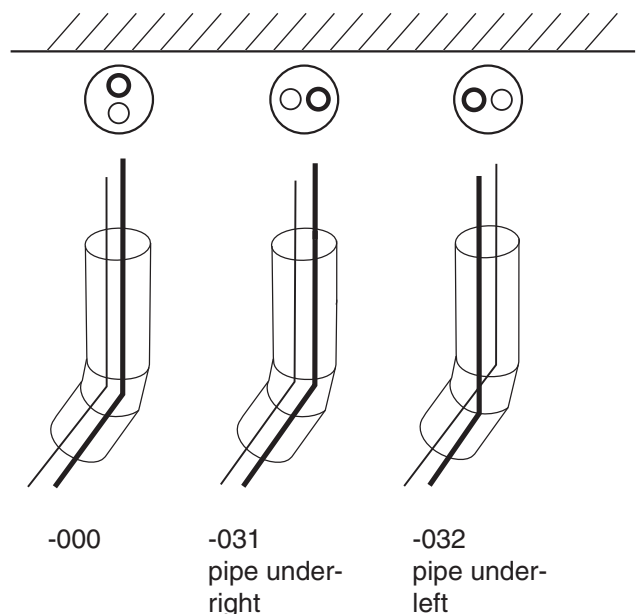

Please observe: Do not refill above the sealing.

The sealing shall not be below water table continuously.

DOUBLE PIPES

4:203

Termination bend for Facade adaptering, DN 20-25

PN 16/PN25

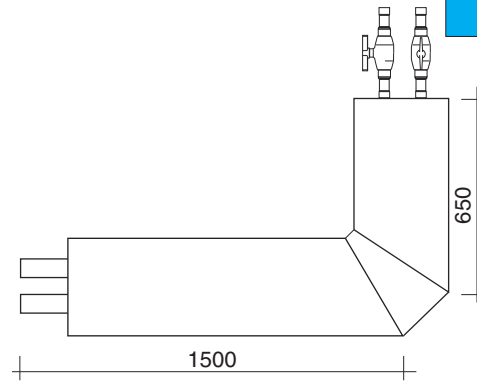

ARTIKEL NO 2540, 2640, 2740

DN	Service pipe Dy x s [mm]	Standard 2540 Jacket pipe Dy [mm]	Double+ 2640 Jacket pipe Dy [mm]	Double++ 2740 Jacket pipe Dy [mm]
20	26,9 x 2,0	140	160	180
25	33,7 x 2,3	140	160	180

Termination bend designed for façade installation comes with DN 20 valve and extended neck.
Red handles are adaptered on the front line, blue on the return line.
Termination bend can be delivered with extended length of bend length - 10 m
Available in angled design.

Article No..

2540-DN-000-000 (STANDARD)
2640-DN-000-000 (DOUBLE+)
2740-DN-000-000 (DOUBLE++)

An example of how to order:

Termination bend for facade installation, DN25 with
handle right has Article No. 2540-025-000-031.

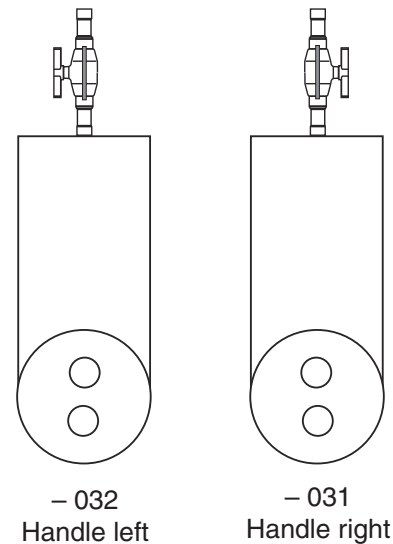

NOTE: The valves must be operated at least twice a year to ensure proper function.

DOUBLE PIPES

4:204

Profile bend

PN 16/PN25

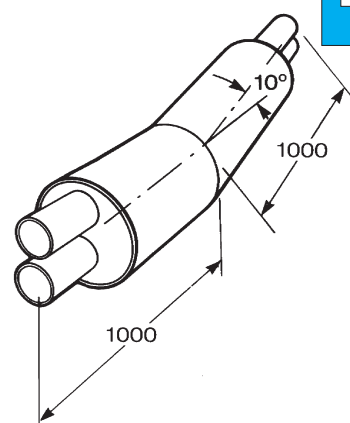

PROFILE BEND 2520, 2620, 2720		STANDARD 2520	DOUBLE+ 2620	DOUBLE++ 2720
DN	Service pipe Dy x s [mm]	Jacket pipe Dy [mm]	Jacket pipe Dy [mm]	Jacket pipe Dy [mm]
25	33,7 x 2,3	140	160	180
32	42,4 x 2,6	160	180	200
40	48,3 x 2,6	160	180	200
50	60,3 x 2,9	200	225	250
65	76,1 x 2,9	225	250	280
80	88,9 x 3,2	250	280	315
100	114,3 x 3,6	315	355	400
125	139,7 x 3,6	400	450	500
150	168,3 x 4,0	450	500	560
200	219,1 x 4,5	560		

Bend can be obtained by any angle.

Article No.

2520-DN-000-000 (STANDARD)

2620-DN-000-000 (DOUBLE+)

2720-DN-000-000 (DOUBLE++)

An example of how to order:

Profile bend Double pipe with dim DN 2*80, angle 8° has Article No. 2520-080-008-000.

DOUBLE PIPES

4:205

Bend out of plane

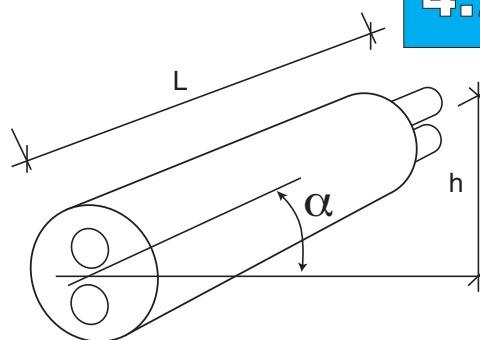

PN 16/PN25

ARTICLE NO. 2510, 2610, 2710

DN	Service pipe Dy x s [mm]	STANDARD	DOUBLE+	DOUBLE++	L x L [mm]
		2510 Jacket pipe DY [mm]	2610 Jacket pipe DY [mm]	2710 Jacket pipe DY [mm]	
25	33,7 x 2,3	140	160	180	1000 x 1000
32	42,4 x 2,6	160	180	200	1000 x 1000
40	48,3 x 2,6	160	180	200	1000 x 1000
50	60,3 x 2,9	200	225	250	1000 x 1000
65	76,1 x 2,9	225	250	280	1000 x 1000
80	88,9 x 3,2	250	280	315	1000 x 1000
100	114,3 x 3,6	315	355	400	1000 x 1000
125	139,7 x 3,6	400	450	500	1000 x 1000
150	168,3 x 4,0	450	500	560	1200 x 1200
200	219,1 x 4,5	560			1200 x 1200

Standard degree of bend
horisontally is 90°
Angle in profile is optional.

α°	3	5	7,5	10	12,5	15	20	25
h(mm)	50	90	180	170	215	260	240	420

Article No..

2510-DN-000-031

STANDARD, Right hand design

2510-DN-000-032

STANDARD, Left hand design

2610-DN-000-031

DOUBLE+, Right hand design

2610-DN-000-032

DOUBLE+, Left hand design

2710-DN-000-031

DOUBLE++, Right hand design

2710-DN-000-032

DOUBLE++, Left hand design

An example of how to order:

Bend Double pipe with dim DN 2*80, 90°, standard, right hand design
has Article No. 2510-080-000-031.

Angle of deflection has to be written in a separate text line.

DOUBLE PIPES

4:301

T-piece

Powerpipe T-pieces are as standard delivered in a reinforced design, increased thickness and, if necessary, increased steel quality. Branch can be installed without discharging dog leg.

PN 16/PN25

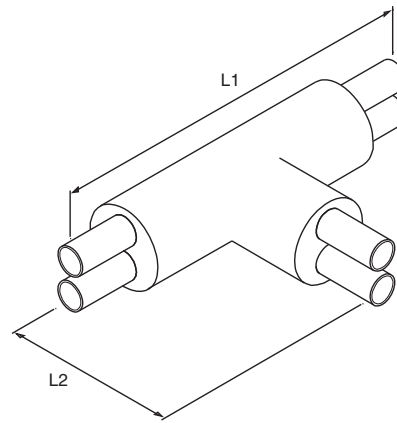

ARTICLE NO. 3510, 3610, 3710

Main pipe DN	Branch pipe DN	L1 [mm]	L2 [mm]	STANDARD 3510 Jacket pipe Dy [mm]	DOUBLE+ 3610 Jacket pipe Dy [mm]	DOUBLE++ 3710 Jacket pipe Dy [mm]
25-200	25-100	1200	700	25	140	180
125-200	125-150	1500	700	32	160	200
200	200	1500	800	40	160	200
				50	200	250
				65	225	280
				80	250	315
				100	315	400
				125	400	500
				150	450	560
				200	560	

The branch pipe cannot be designed in dimensions bigger than the main pipe.

Article No..

3510-DN main pipe -DN branch pipe-000 (Standard)
 3610-DN main pipe -DN branch pipe-000 (Double+)
 3610-DN main pipe -DN branch pipe-000 (Double++)

Space for sleeve

In order to adequately fit sleeve when installing T-piece, we offer a version with extension:
 L1- dimension by 200 mm.
 L2- dimension by 1.000 mm.
 State suffix: 999.

An example of how to order:

T-piece Double pipe with main pipe DN 2*100, standard, and branch pipe DN 2*50, has Article No. 3510-100-050-000.
 Alt. (extended T-piece) has Article No. 3510-100-050-999

DOUBLE PIPES

4:302

Intersection unit

T-pieces are as standard delivered in a reinforced design, increased thickness and, if necessary, increased steel quality. Branch can be installed without discharging dog leg.

PN 16/PN25

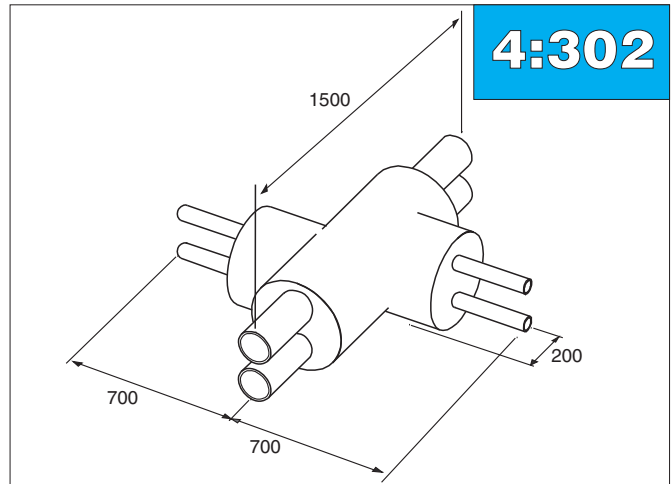

ARTICLE NO. 3570, 3670, 3770

Main pipe DN	Branch pipe DN	DN	STANDARD 3570	DOUBLE+ 3670	DOUBLE++ 3770
			Jacket pipe Dy [mm]	Jacket pipe Dy [mm]	Jacket pipe Dy [mm]
25-200	25-65	25	140	160	180
		32	160	180	200
		40	160	180	200
		50	200	225	250
		65	225	250	280
		80	250	280	315
		100	315	355	400
		125	400	450	500
		150	450	500	560
		200	560		

The branch pipe cannot be designed in dimensions larger than the main pipe. Powerpipe can on request deliver T-pieces in a non reinforced design.

Article No.

- 3570-DN main pipe-DN branch pipe-000 (STANDARD)
- 3670-DN main pipe-DN branch pipe-000 (DOUBLE+)
- 3770-DN main pipe-DN branch pipe-000 (DOUBLE++)

An example of how to order:

Intersection unit with main pipe DN 2*65, standard, and branch pipe DN 2*32 has Article No. 3570-065-032-000.

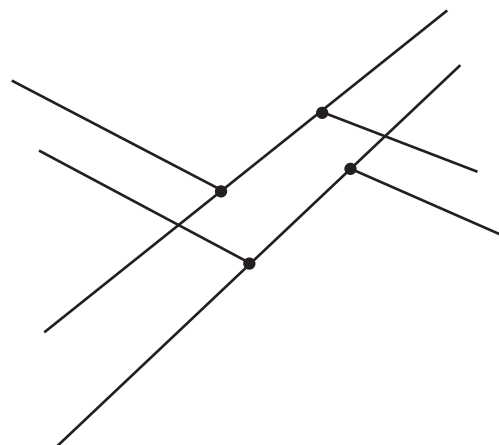

DOUBLE PIPES

4:303

T-piece with horizontal deflection

Powerpipe T-pieces are as standard delivered in a reinforced design and if necessary with increased steel quality.

Must be installed with discharging dog leg.

PN 16/PN25

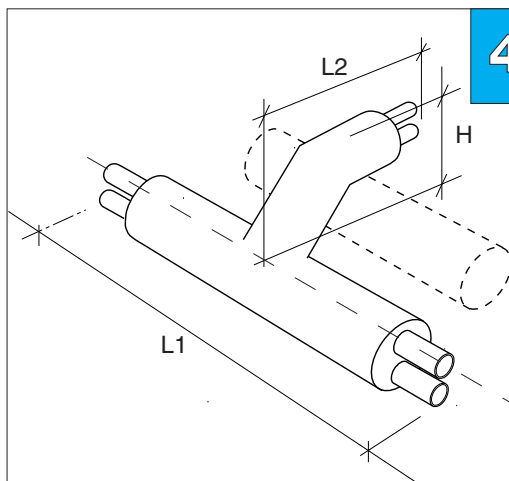

ARTICLE NO. 3510, 3610, 3710

Main pipe DN	Branch pipe DN	L1 [mm]	L2 [mm]	DN	STANDARD 3510 Jacket pipe Dy [mm]	DOUBLE+ 3610 Jacket pipe Dy [mm]	DOUBLE+ 3710 Jacket pipe Dy [mm]			
25-100	25-100	1200	1000	25	140	160	180			
				32	160	180	200			
				40	160	180	200			
125-200	25-100	1200	1200	50	200	225	250			
				125-200	1500	1500	65	225	250	280
							80	250	280	315
							100	315	355	400
							125	400	450	500
150	450	500	560							
				200	560					

H= Dy main pipe + 50 mm.

The branch pipe cannot be designed in dimensions bigger than the main pipe.

NOTE! The branch pipe on the T-piece out of plane will need a discharging dog leg.

Article No..

3510-DN main pipe-DN branch pipe-238 (STANDARD)

3610-DN main pipe-DN branch pipe-238 (DOUBLE+)

3710-DN main pipe-DN branch pipe-238 (DOUBLE++)

An example of how to order:

T-piece Double pipe

with main pipe DN 2*100, standard, and branch pipe DN 2*50,

has Article No. 3510-100-050-238.

DOUBLE PIPES

4:304

T-piece Double/single

Powerpipe T-pieces are as standard delivered in a reinforced design and if necessary with increased steel quality.

Branch pipe can be installed without discharging dog leg.

PN 16/PN25

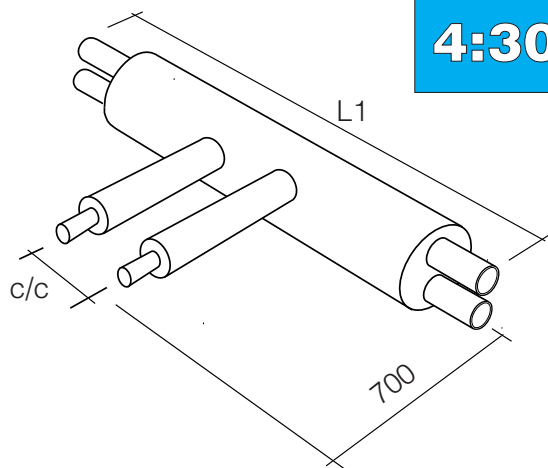

ARTICLE NO. 3520, 3620, 3720

Main pipe DN	Branch pipe [mm]	L1 [mm]	Branch pipe	c/c
DN 2*25-200	DN20-80	1500	20	310
			25	310
			32	325
			40	325
			50	340
			65	360
			80	380

As standard the branch pipe is insulated according to Series 2.

Article No..

3520-DN main pipe-DN branch pipe-000 (STANDARD)

3620-DN main pipe-DN branch pipe-000 (DOUBLE+)

3720-DN main pipe-DN branch pipe-000 (DOUBLE++)

An example of how to order:

T-piece Double/single standard design with main pipe DN 2*65 and branch pipe DN 25 (Series 2) has Article No. 3520-065-025-000

DOUBLE PIPES

4:305

Transition unit single-double pipe, knee type

PN 16/PN25

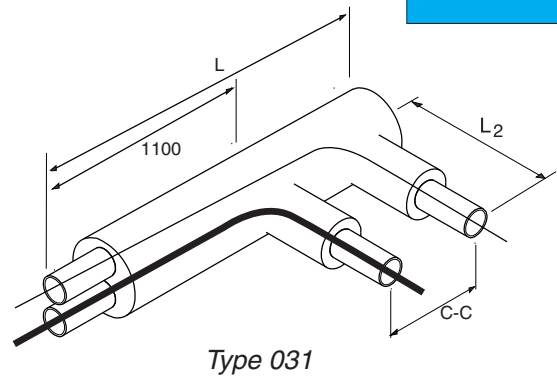

ARTICLE NO. 1580, 1680, 1780

Dim DN	C-C [mm]	L [mm]	L2 [mm]
25	310	1410	700
32	330	1430	700
40	330	1430	700
50	340	1440	700
65	360	1460	700
80	380	1480	700
100	475	1575	700
125	500	1600	700
150	530	1630	700
200	605	1705	900

NOTE! This solution is not designed to absorb axial forces or movements from single pipes. Branches for single pipes are delivered in Series 2.

F = Flow (marked with a white dot on the steel pipe).

R = Return

Article No..

- 1580-DN-000-031 (STANDARD)
- 1580-DN-000-032 (STANDARD)
- 1680-DN-000-031 (DOUBLE+)
- 1680-DN-000-032 (DOUBLE+)
- 1780-DN-000-031 (DOUBLE++)
- 1780-DN-000-032 (DOUBLE++)

An example of how to order:
Transition unit DN 50, standard, right hand flow has Article No. 1580-050-000-032.

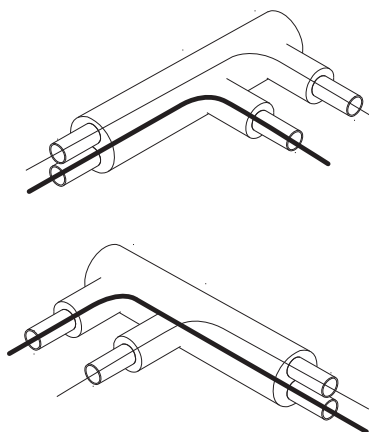

Left hand flow
with flowpipe under
031

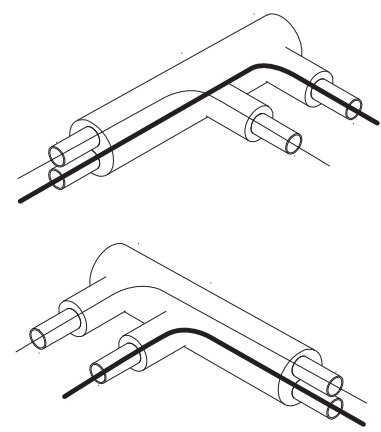

Right hand flow
with flowpipe under
032

DOUBLE PIPES

4:306

Transition unit single - double pipe, straight type

Can be used between single and double pipes at big expansion forces.

PN 16/PN25

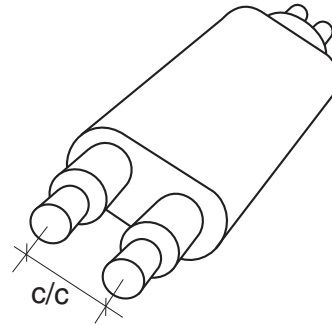

Left hand flow type 000

ARTICLE NO. 1590, 1690, 1790

DN	C-C [mm]	L [mm]
25	310	1600
32	330	1600
40	330	1600
50	340	1600
65	360	1600
80	380	1800
100	475	1800
125	500	2000
150	530	2100
200	600	2250

Branches for single pipe are delivered in Series 2.

Article No..

1590 DN main pipe-000-000 right hand flow STANDARD

1590 DN main pipe-000-029 left hand flow STANDARD

1690 DN main pipe-000-000 right hand flow DOUBLE+

1690 DN main pipe-000-029 left hand flow DOUBLE+

1790 DN main pipe-000-000 right hand flow DOUBLE++

1790 DN main pipe-000-029 left hand flow DOUBLE++

An example of how to order:

Transition unit single-double pipe, straight ,
DN 50, standard, left hand flow has
Article No. 1590-050-000-029.

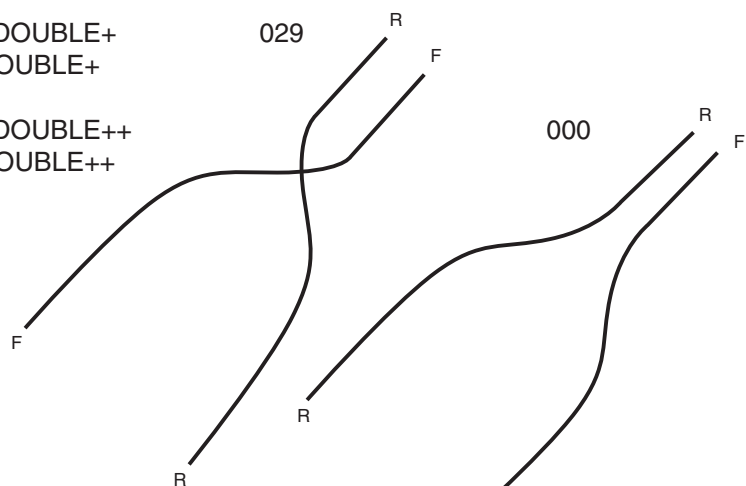

Left hand flow
Flowpipe under
031

Right hand flow
Flowpipe under
032

DOUBLE PIPES

4:401

Preinsulated valves

The unit consists of a maintenance free ball valve in a fully welded housing together with a corrosion free ball. All valves according to EN448 are supplied to stand the yield strength as the pipe line.

The alarmwire are linked outside the sealing.

PN 16/PN25

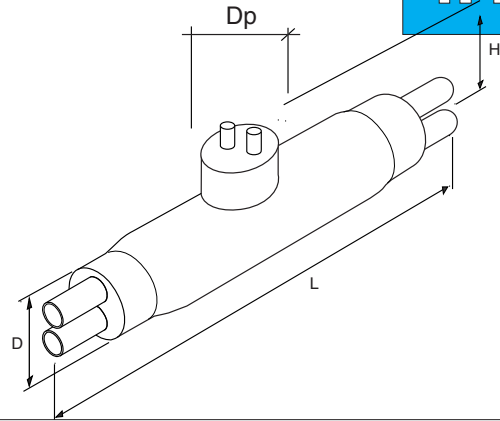

ARTICLE NO. 4500, 4600, 4700

DN	Service pipe 2 pc Dy x s [mm]	STANDARD	DOUBLE+	DOUBLE++	L [mm]	H [mm]	Dp [mm]	Wrench size [mm]	
		4500 Jacket pipe DY [mm]	4600 Jacket pipe DY [mm]	4700 Jacket pipe DY [mm]					
25	33,7 x 2,3	140	160	180	1700	409	150	19	} Adapter for T-key
32	42,4 x 2,6	160	180	200	1700	422	170	19	
40	48,3 x 2,6	160	180	200	1700	435	170	19	
50	60,3 x 2,9	200	225	250	1700	451	190	19	
65	76,1 x 2,9	225	250	280	1700	463	190	19	
80	88,9 x 3,2	250	280	315	1900	483	190	19	
100	114,3 x 3,6	315	355	400	2150	519	235	27	} Adapter for portable gear
125	139,7 x 3,6	400	455	500	2200	540	235	27	
150	168,3 x 4,0	450	500	560	2550	578	295	27	
200	219,1 x 4,5	560			2600	652	295	50	

The valve is protected by a hut of stainless steel as a standard. Please see 8:102

Article No..

4500-DN-000-000 (STANDARD)

4600-DN-000-000 (DOUBLE+)

4700-DN-000-000 (DOUBLE++)

An example of how to order:

Preinsulated valve for main pipe dim DN 2*100, standard has Article No. 4500-100-000-000.

Please observe: the included ball valve has to be operated at least twice/ year in order to ensure a good function.

Please observe: Do not refill above the sealing.
The sealing shall not be below water table continuously.

DOUBLE PIPES

4:402

Valve unit, Compact

PN 16/PN25

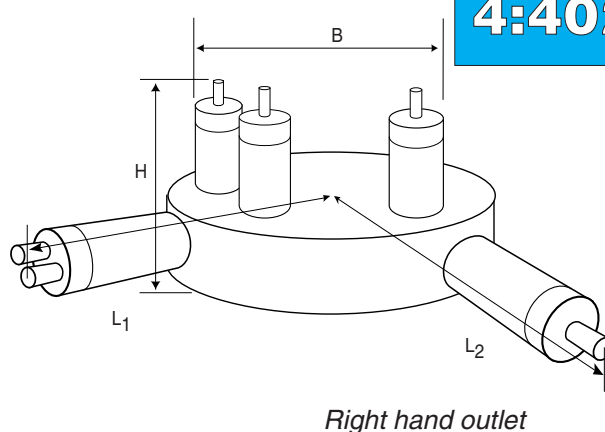

ARTICLE NO. 4570, 4670, 4770

DN	Standard 4570 Service pipe Dy[mm]	Double+ 4670 Dy[mm]	Double++ 4770 Dy[mm]	H Standard [mm]	H Min [mm]	B [mm]	L1 [mm]	L2 [mm]
25	140	160	180	480	190	400	800	500
40	160	180	200	495	200	450	920	705
50	200	225	250	500	210	450	1020	725

The drainage pipe is manufactured in stainless steel.

Article No..

4570-DN-000-000 (STANDARD)

Right hand outlet has prefix 031

Left hand outlet has prefix 032.

Valve unit with minimal stem height specifies separately.

An example of how to order:

Valve unit, compact, right hand outlet standard design dim DN50 has Article No. 4570-050-000-031.

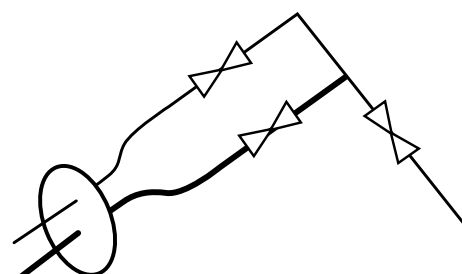

Right hand outlet

Please observe: the included ball valve has to be operated at least twice/ year in order to ensure a good function.

Please observe: Do not refill above the sealing.
The sealing shall not be below water table continuously.

DOUBLE PIPES

4:403

Valve unit, direct

The unit can be used as both drainage and air release

PN 16/PN25

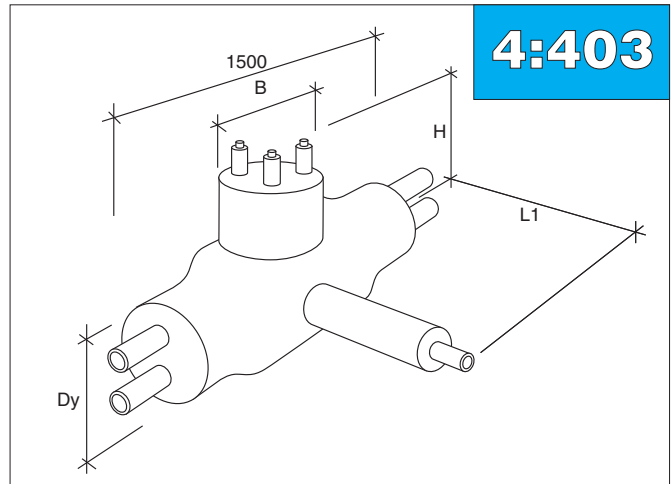

ARTICLE NO. 4575, 4675, 4775

DN	Dy x s [mm]	STANDARD	DOUBLE+	DOUBLE++	L1 [mm]	DN Out	Wrench size [mm]	B [mm]	H [mm]
		4575	4675	4675					
		Jacket pipe DY [mm]	Jacket pipe DY [mm]	Jacket pipe DY [mm]					
40	48,3 x 2,6	160	180	200	550	25	19	295	480
50	60,3 x 2,9	200	225	250	555	25	19	295	480
65	76,1 x 2,9	225	250	280	565	25	19	295	480
80	88,9 x 3,2	250	280	315	640	32	19	295	485
100	114,3 x 3,6	315	355	400	720	40	27	295	485
125	139,9 x 3,6	400	450	500	720	40	27	315	485
150	168,3 x 4,0	450	500	560	720	40	27	315	485

Article No.

4575-DN main pipe-000-000 (STANDARD)

4675-DN main pipe-000-000 (DOUBLE+)

4775-DN main pipe-000-000 (DOUBLE++)

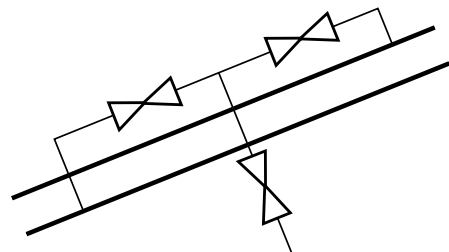

An example of how to order:

Valve unit left, double pipe standard with Dim DN 2 * 50 (with air release/drainage DN 25) has Article No. 4575-050-000-000.

Please observe: the included ball valve has to be operated at least twice/ year in order to ensure a good function.

Please observe: Do not refill above the sealing. The sealing shall not be below water table continuously.

DOUBLE PIPES

4:404

Air release/ drainage

The alarmwires are linked outside the sealing.

PN 16/PN25

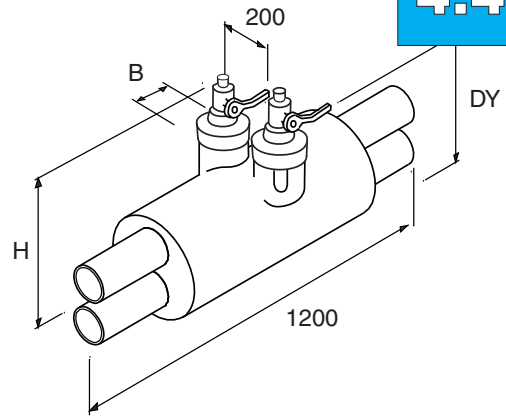

ARTICLE NO. 3540, 3640, 3740

Main pipe DN	Service pipe 2 pc Dy x s [mm]	STANDARD 3540 Jacket pipe DY [mm]	DOUBLE+ 3640 Jacket pipe DY [mm]	DOUBLE++ 3740 Jacket pipe DY [mm]	H [mm]	Air release/drainage DN	B-measure [mm]
25	33,7 x 2,3	140	160	180	437	25	110
32	42,4 x 2,6	160	180	200	445	40	110
40	48,3 x 2,6	160	180	200	451	50	125
50	60,3 x 2,9	200	225	250	463	65	140
65	76,1 x 2,9	225	250	280	479		
80	88,9 x 3,2	250	280	315	495		
100	114,3 x 3,6	315	355	400	520		
125	139,7 x 3,6	400	450	500	548		
150	168,3 x 4,0	450	500	560	581		
200	219,1 x 4,5	560			634		

Air release/ drainage units manufactured in dimensions dim. DN 25, DN 40, DN 50 och DN 65.

Air release/ drainage units are delivered with a screwed on plug.

The valve is protected by a end cap as a standard. Please see 8:102

Article No..

3540-DN main pipe-DN air release-000 (STANDARD)

3640-DN main pipe-DN air release-000 (DOUBLE+)

3740-DN main pipe-DN air release-000 (DOUBLE++)

An example of how to order:

Air release unit for main pipe dim DN 2*100, standard and air release unit DN 25, has Article No. 3540-100-025-000.

Please observe: the included ball valve has to be operated at least twice/year in order to ensure a good function.

Please observe: Do not refill above the sealing. The sealing shall not be below water table continuously.

DOUBLE PIPES

4:405

Valve unit with air release on one or both sides

Valve units are delivered in conformance with Swedish District Heating Association's delivery requirements and EN 488.

PN 16/PN25

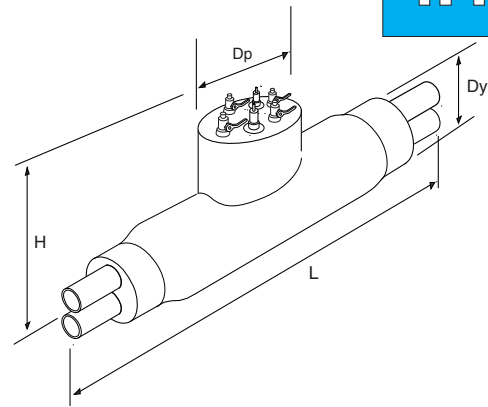

VALVE UNIT WITH AIR RELEASE ON ONE OR BOTH SIDES 4541, 4542, 4641, 4642

	STANDARD 4541, 4542	DOUBLE+ 4641, 4642	DOUBLE++ 4741, 4742				
DN	Jacket pipe Dy [mm]	Jacket pipe Dy [mm]	Jacket pipe Dy [mm]	L [mm]	H [mm]	Dp [mm]	Wrench size [mm]
40	160	180	200	1.700	440	235	19
50	200	225	250	1.700	451	295	19
65	225	250	280	1.700	463	295	19
80	250	280	315	1.900	483	295	19
100	315	355	400	2.150	519	295	27
125	400	450	500	2.200	540	340	27
150	450	500	560	2.550	578	415	27

Adapter for T-key
Adapter for portable gear

Air release delivered in DN25.

Available with pulled-up alarm wires
Air release on one side has Article no 4541
Air release on both sides has Article no 4542

Article No..

4541-DN-000-000 (STANDARD) with one air release
4542-DN-000-000 (STANDARD) with two air releases

4641-DN-000-000 (DOUBLE+) with one air release
4642-DN-000-000 (DOUBLE+) with two air releases

4741-DN-000-000 (DOUBLE++) with one air release
4742-DN-000-000 (DOUBLE++) with two air releases

An example of how to order:

Valve unit with air release on both sides DN 2*80, standard has Article No. 4542-080-000-000.

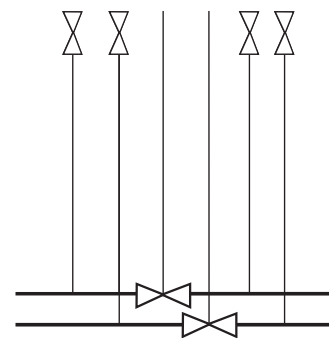

Principle sketch

Please observe: the included ball valve has to be operated at least twice/year in order to ensure a good function.

Please observe: Do not refill above the sealing. The sealing shall not be below water table continuously.

DOUBLE PIPES

4:406

Combination valve Double, double sided

Valve units are delivered in conformance with Swedish District Heating Association's delivery requirements and EN 488.

The alarmwires are linked outside the sealing.

PN 16/PN25

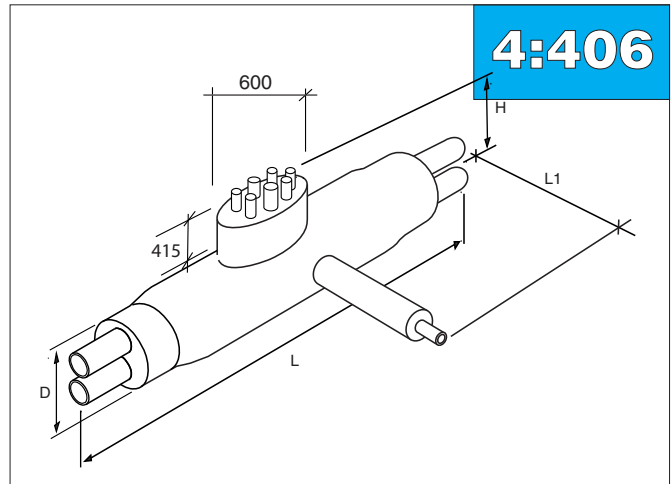

ARTICLE NO. 4845, 4846, 4847

DN	Service pipe 2 pc Dy x s [mm]	STANDARD	DOUBLE+	DOUBLE++	L [mm]	H [mm]	L1 [mm]	Dp [mm]	Wrench size [mm]
		4845 Jacket pipe DY [mm]	4846 Jacket pipe DY [mm]	4847 Jacket pipe DY [mm]					
40	48,3 x 2,6	160	180	200	1600	435	700		19 *
50	60,3 x 2,9	200	225	250	1700	451	700	230	19 *
65	76,1 x 2,9	225	250	280	1700	463	700	230	19 *
80	88,9 x 3,2	250	280	315	1900	483	700	230	19 *
100	114,3 x 3,6	315	355	400	2150	519	700	230	27 *
125	139,7 x 3,6	400	455	500	2200	540	700	230	27 *
150	168,3 x 4,0	450	500	560	2550	578	700		27 **
200	219,1 x 4,5	560			2600	652	900		50 **

* Adapter for T-key

** Adapter for portabel gear

Air release in DN25

The valve is protected by a end cap as a standard.

See page 8:102

Article No.

4845-DN-000-000 (STANDARD)

4846-DN-000-000 (DOUBLE+)

4847-DN-000-000 (DOUBLE++)

An example of how to order:

Combination valve, double pipe standard design in dim DN 2* 100, has Article No.

4845-100-000-000.

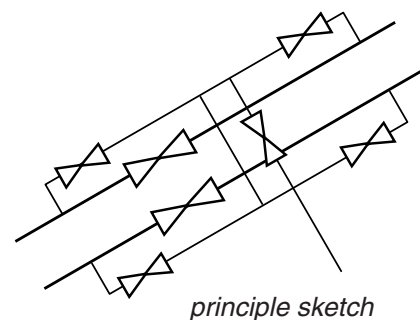

principle sketch

Please observe: the included ball valve has to be operated at least twice/year in order to ensure a good function.

Please observe: Do not refill above the sealing. The sealing shall not be below water table continuously.

DOUBLE PIPES

4:407

Combination valve Double, double sided

Valve units are delivered in conformance with Swedish District Heating Association's delivery requirements and EN 488.

The alarmwires are linked outside the sealing.

PN 16/PN25

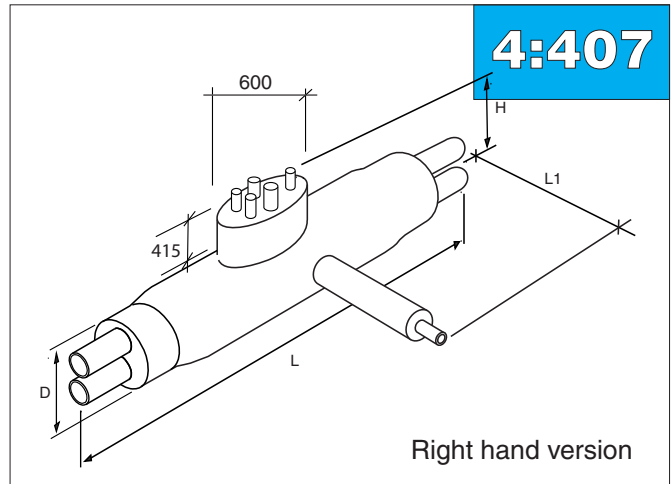

Right hand version

ARTICLE NO. 4745, 4746, 4747

DN	Service pipe 2 pc Dy x s [mm]	STANDARD	DOUBLE+	DOUBLE++	L [mm]	H [mm]	L1 [mm]	Dp [mm]	Wrench size [mm]
		4745 Jacket pipe DY [mm]	4746 Jacket pipe DY [mm]	4747 Jacket pipe DY [mm]					
40	48,3 x 2,6	160	180	200	1600	435	700		19 *
50	60,3 x 2,9	200	225	250	1700	451	700	230	19 *
65	76,1 x 2,9	225	250	280	1700	463	700	230	19 *
80	88,9 x 3,2	250	280	315	1900	483	700	230	19 *
100	114,3 x 3,6	315	355	400	2150	519	700	230	27 *
125	139,7 x 3,6	400	455	500	2200	540	700	230	27 *
150	168,3 x 4,0	450	500	560	2550	578	700		27 **
200	219,1 x 4,5	560			2600	652	900		50 **

* Adapter for T-key

** Adapter for portabel gear

Air release in DN25

The valve is protected by a end cap as a standard.

See page 8:102

Article No.

4745-DN-000-000 (STANDARD)

4746-DN-000-000 (DOUBLE+)

4747-DN-000-000 (DOUBLE++)

Right hand version has prefix 031

Left hand version has prefix 032

An example of how to order:

Combination valve, double pipe, right hand version
dim DN 2* 100, has Article No. 4745-100-000-031.

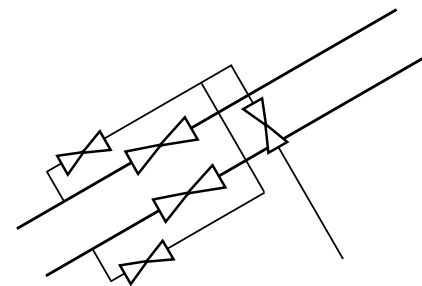

principle sketch,
right hand version 031prefix

Please observe: the included ball valve has to be operated at least twice/year in order to ensure a good function.

Please observe: Do not refill above the sealing.
The sealing shall not be below water table continuously.

DOUBLE PIPES

4:408

Valve unit with protected air release/drainage

The alarmwires are linked outside the sealing.

PN 16/PN25

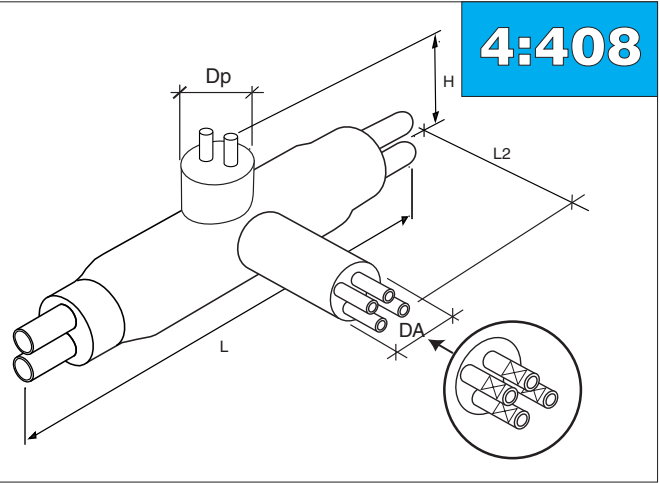

ARTICLE NO. 4542, 4642, 4742, in design 635

Air release/drainage

Main pipe DN	L [mm]	Dp [mm]	Air release DN [mm]	H [mm]	Wrench size [mm]	DN	DA [mm]	L2 [mm]
40	1700	230	25	435	19	25	305	300
50	1700	230	25	451	19			
65	1700	230	25	463	19			
80	1900	230	25	483	19			
100	2150	230	25	519	27			
125	2200	230	25	540	27	Adapter for portable gear		
150	2250	230	25	578	27			
200	2600	230	25	652	50			

Air release-/drainage valves are equipped with stainless steel screw plugs and are available in dimensions DN 25.

Connections can be made in the threaded end.

Valve stems are facing upwards. Delivered with the same dimensions on both air release / drainage valves.

The valve is supplied with end cap for spindle as standard.
See page 8:102

An example of how to order:

Ventil series 2 with main pipe DN 2*100 and air release DN 25 in 635 design, has Article No.4542-100-025-635.

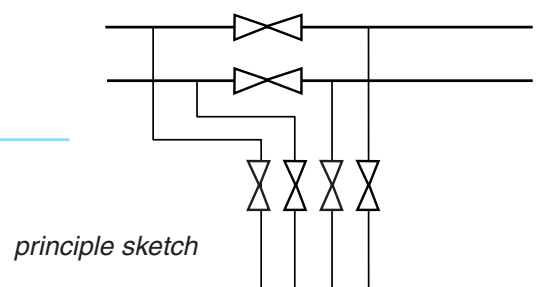

Please observe: the included ball valve has to be operated at least twice/year in order to ensure a good function.

Please observe: Do not refill above the sealing. The sealing shall not be below water table continuously.

DOUBLE PIPES

4:501

Fixed pipe section

Pipe lines installed with double pipes which are not terminated by a bend, transition unit, valve or T-piece shall be completed with a fixed pipe section before pre-heating/ commissioning of the pipe line. Alternatively, steel pipes fixed with fixplates according to the manufacturer's instructions.

PN 16/PN25

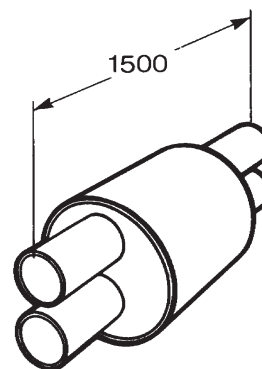

FIXED PIPE SECTION 1520, 1620

	STANDARD 1520	DOUBLE+ 1620	DOUBLE++ 1720
DN	Jacket pipe Dy [mm]	Jacket pipe Dy [mm]	Jacket pipe Dy [mm]
25	140	160	180
32	160	180	200
40	160	180	200
50	200	225	250
65	225	250	280
80	250	280	315
100	315	355	400
125	400	450	500
150	450	500	560
200	560		

Article No..

1520-DN-000-000 (STANDARD)

1620-DN-000-000 (DOUBLE+)

1720-DN-000-000 (DOUBLE++)

An example of how to order:

Fixed pipe section for a main Double pipe DN 2 x 50, standard has Article No. 1520-050-000-000.

DOUBLE PIPES

4:502

Anchor unit

The anchor unit is designed for casting into concrete. Dimensioning pressure force in concrete 5 MN/ m² (50 kg/ cm²), standard value in ground 0,15 MN/ m² (1,5 kg/ cm²), standard value.

PN 16/PN25

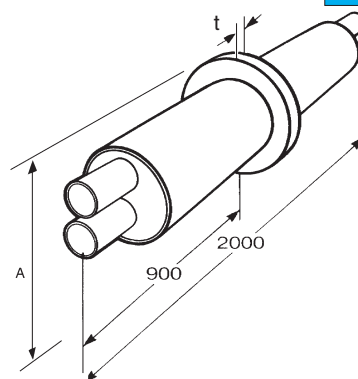

ANCOR UNIT 5500, 5600, 5700

DN	Max load (kN) ØT = 60°C	A [mm]	t [mm]	Pressure area [cm ²]
25	63	250	20	337
32	82	300	20	505
40	93	300	20	505
50	130	300	20	390
65	167	350	30	565
80	215	400	30	765
100	315	450	30	810
125	385	550	35	1120
150	515	650	40	1720
200	750	750	40	1950

ØT is the deviation from the average operating temperature of the pre-insulated pipe line

$$\frac{(T_f \times T_r)}{2}$$

T_p = flow line temperature
T_r = return line temperature

Article No.

5500-DN-000-000 (STANDARD)

5600-DN-000-000 (DOUBLE+)

5700-DN-000-000 (DOUBLE++)

An example of how to order:

Anchor unit for DN 2*50, standard, has Article No.5500-050-000-000.

DOUBLE PIPES

4:503

Reduction unit

Alternatively, the reduction can be carried out in the field with eccentric steel cones and reducer casings.

PN 16/PN25

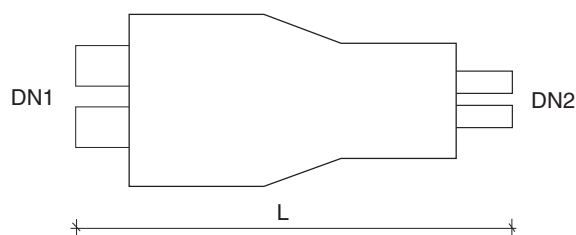

REDUCTION UNIT 1575, 1675, 1775

DN1/DN2	DN25	DN32	DN40	DN50	DN65	DN80	DN100	DN125	DN150	Length [mm]
32	x									1100
40	x	x								1100
50		x	x							1100
65			x	x						1100
80				x	x					1100
100					x	x				1100
125						x	x			1100
150							x	x		1300
200								x	x	1300

The detail is used at change of dimension
Table gives the standard dimension for reduction unit.

Article No..

1575-DN1-DN2-000 (STANDARD)

1675-DN1-DN2-000 (DOUBLE+)

1775-DN1-DN2-000 (DOUBLE++)

An example of how to order:

Reduction unit for pipes DN 2*50 to DN 2*40
has Article No. 1575-050-040-000.

NOTE:

Consult the designer where the reduction has to be placed and what size.